

**ROT-X-TRACT-L<sup>TM</sup>**  
**Liquid/Liquid Extraction System**

**Model 13308**

**INSTRUCTION MANUAL**  
**for**  
**STANDARD LIQUID / LIQUID**  
**EXTRACTION**

**ORGANOMATION ASSOCIATES INC.**

266 RIVER ROAD WEST  
BERLIN, MA 01503  
U. S. A.

Tel: 888-838-7300

Fax: 978-838-2786



**Introduction**

Instrument Items Shipped	4
Instrument Description	7

**Installation**

Location	9
Bath Setup	9
Instrument Setup	12

<b>Safety Considerations - Read before operation</b>	16
--	----

**Operation**

Instrument Control Identification	15
Planning and Preparation	17
Type Z Purge Positive Pressure Bath Option	11, 20
Operation	18

<b>Maintenance and Cleaning</b>	21
---------------------------------	----

<b>Trouble Shooting</b>	22
-------------------------	----

**Technical Information**

Parts List	4
Service and Returns	23
Shipping - Claims for damage or shortage	24
Specifications	25
Wiring Diagrams	26

<b>Contacting Organomation and its Representatives</b>	24
--	----

**Items Shipped**

Carefully check the contents of all cartons received for damage which may have occurred in transit. Retain all cartons and packaging materials until all components have been checked against the packing slip, the component list below, and the equipment has been assembled and tested. Contact Organomation Associates Inc. immediately if any damage or discrepancies are found.

Your shipment should contain one or more of the instruments and / or glass sets shown below. Option codes are listed on the next page.

<b>Cat #</b>	<b>Instruments Only (Glassware Sold Separately)</b>
<b>13308</b>	<p><b>8 Position ROT-X-TRACT-L,</b></p> <p style="padding-left: 40px;"><b>8 Position heating unit, 120 or 240 VAC.</b>  <b>Condenser Water Manifold Assembly</b>  <b>SS support rod</b>  <b>Extractor support system</b>  <b>Cover disk and hole covers</b>  <b>Tubing, Manual, Assembly Tools</b></p> <p><b>Water / Power Control Box, includes: pressure reducing regulator, filter, flow meter, water connection tubing, energy control for heat, low flow line break protection circuit for water system.</b></p>

**Glassware Sets**

<b>GS3357</b>	<p>1 Position Liquid-Liquid Extractor Set, includes:</p> <p style="padding-left: 40px;">1 each: KD Flask 250mL                      1 each: 1000mL extractor body                      1 each: concentrator tube                      1 each: Allihn condenser</p>
---------------	--

**GS3358**

1 Position Liquid-Liquid Extractor Set, includes:

- 1 each: RB Flask 250mL
- 1 each: 1000mL extractor body
- 1 each: Allihn condenser

**GS3352**

1 Position Hershberg-Wolfe Liquid-Liquid Extractor Set, includes:

- 1 each: KD Flask 250mL
- 1 each: H-W 1000mL extractor body
- 1 each: concentrator tube
- 1 each: Allihn condenser
- 1 each: Frit

**GS3362**

1 Position Hershberg-Wolfe Liquid-Liquid Extractor Set, includes:

- 1 each: RB Flask 250mL
- 1 each: H-W 1000mL extractor body
- 1 each: Allihn condenser
- 1 each: Frit

**Option Codes and additional items shipped**

The following list contains option codes and items which may have been shipped in conjunction with the standard parts shown on the previous pages. Please check your packing list and order information carefully to determine if these items are included in your shipment.

Your shipment may contain the following optional items:

<b>Option</b>	<b>Description</b>
<b>-Z</b>	OA-SYS water bath has been modified for the Type-Z Purge Positive pressure bath option. Additional parts include: differential pressure gauge, mounting bracket, and tubing.
<b>-2</b>	OA-SYS water bath is wired as a 240 Volt unit.

Teflon is a registered trademark of EI Dupont Inc.

### Instrument Description

The ROT-X-TRACT Solvent Extraction System is designed for general evaporation and concentration of analytical or environmental samples to meet the needs of specific methods under controlled and reproducible conditions.

The ROT-X-TRACT system features liquid / liquid extraction with solvent vapor recovery. Solvent recoveries can exceed 90% by volume under ideal conditions. The system may be used with cold tap water or a recirculating chiller system. The temperature controlled water bath provides even uniform heating without scalding final samples. The parallel water manifold system provides even cooling water to each of the eight condensers. The rotary water manifold allows unlimited instrument rotation for front loading without condenser tubing wrapping about the instrument.



Figure 1

CONTROL BOX - TOP VIEW

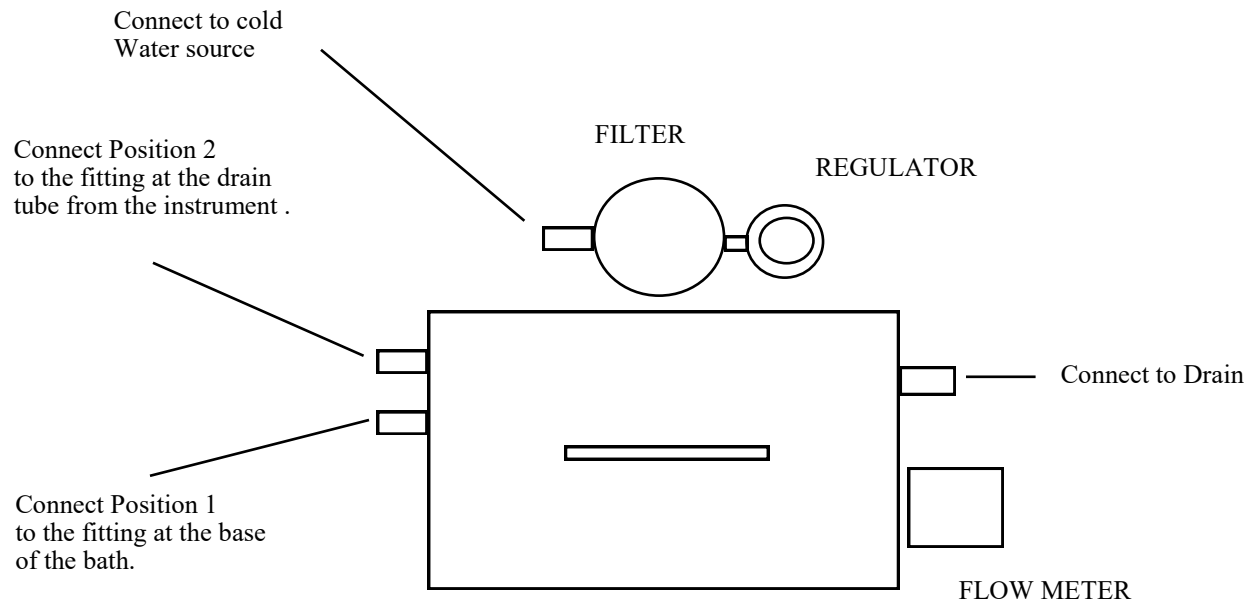



**Location**

The ROT-X-TRACT evaporator system should be located on a bench top or in a chemical fume hood if hazardous or flammable materials and solvents are to be used. The location should provide the necessary support services for the instrument. These include electrical power (required for water bath), cold water. Please review the Specifications Section for further information.

**Bath and Control Box Setup**

1. Position the bath on a stable flat surface such as a lab bench or in a chemical fume hood.
2. Position the control box on a flat surface within six feet of the ROT-X-TRACT bath.
3. Connect the twist lock power cord from the rear of the bath to the connector on the back of the control box.
4. Set all controls on the control box to their “off” positions.
5. Plug the control box electrical cord into a 3 wire grounded electrical outlet rated for 110-120 VAC, 50-60 Hz, single phase, 15 amps.

Optional 220 VAC units are clearly marked and should be plugged into a three wire grounded electrical outlet rated for 220-240 VAC, 50-60 Hz, single phase, 15 amps.

6. Connect the filter inlet on the rear of the control box to a suitable cold water source. Do not turn on the water to the instrument.
7. Connect the drain tube to a suitable water drain.
8. Connect the tube connected to position 1 on the control box to the elbow fitting mounted on the side of the bath.

**Proceed to the Instrument Setup and return here when complete.**

9. Turn on water to the control box.
10. Prep water system as follows:
  - A. Install all condensers in instrument.
  - B. Depress reset switch and allow water to flow through the instrument. Condenser should fill from the bottom.
  - C. Check for leaks.

**Bath and Control Box Setup (Continued)**

10. D. Adjust water source and / or pressure regulator until 2500 CCM (2500 ML/min) flow is obtained.
- E. Release reset switch. Water flow should continue without interruption.

**Water Protection System - Description**

The water protection system is designed to prevent water floods in the laboratory. It will also protect water chiller systems from potential damage due to lack of water. The system will activate in the event the return water flow from the instrument drops below 900 CCM. This system protects against water line failures between the control box and the instrument as well as the tubing connections within the instrument. In order to operate properly, **power to the system must be on**. When de-energized manually (turned-off) or in the event of a power failure, the system will allow water to flow without control or protection.

A delay timer is built into the system (16 seconds). During this brief time increment, water will be allowed to flow during a low flow or water line failure event. This protects against momentary pressure fluxuations. It also protects against power fluxuations or outages through the run. In the event of a power failure, water will continue to flow to the samples to prevent solvent loss. When power is restored, the system will automatically re-arm with a 16 second delay to allow water flow to stabilize.

The Water Protection System will also terminate power to the heating unit in the event water flow is terminated to the instrument. This saves the samples from boiling to dryness most of the time (subject to operating conditions and amount of solvent present).

**Bath Setup (Continued)**

11. Type-Z Purge Positive Pressure Bath option - If you do not have this option, please proceed to the next section. Procedures for operating this system may be found in the Operation Section. Quick start instructions are posted on the front of the bath. Please refer to Figure 3 below for parts list and installation.
  - A. Install the Type Z Purge Gauge Assembly to the rear of the bath as shown. The bracket attaches to the rear of the bath and is held in place by a 6-32 x 1/4" screw on the shoulder spacer and by a 1/4" bulkhead hex nut on the gas inlet fitting.
  - B. Connect the small white silicone tube attached to the gauge to the gas inlet fitting using the compression nut provided.
  - C. Attach the filter with 5 foot tube to the plastic elbow fitting located at the base of the bath or control box. Insert the filter into the fitting and tighten the nut. Connect the tube to a clean gas source.
  - D. Test the system by turning on the gas flow to the Z Purge System. Adjust the gas flow until the gauge reads 0.5 inches water pressure. After 10 minutes the gas flow may be adjusted until it reads 0.1 inches water pressure.

**WARNING** - If this unit is located in a hazardous area where volatile fumes are present, the Z-Purge System must be activated for a minimum of 10 minutes prior to activation of bath power. Please review the Safety and Operations sections.

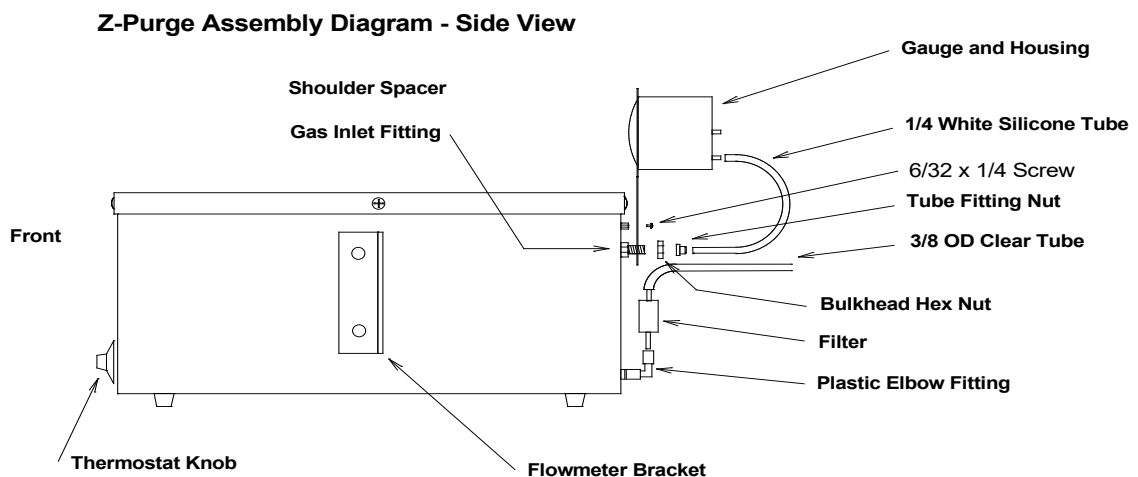

Side mount control box (included on some models) not shown here.

**FIGURE 3**

**Instrument Setup (shipped assembled—follow these instructions if not assembled)**

1. Place the Stainless Steel Rod into the hole in the bottom center of the water bath. Rotate and / or tap in place until it is held firmly in place.
2. Place the large spring over the SS Rod.
3. Place the cover disk assembly on top of the bath rim, it is self centering.
4. Install the SS Thermometer into the fitting on the cover disk assembly. Tighten the nut to secure in place.
5. Place the instrument onto the SS rod in the bath. The SS tube will pass through the collar on the cover disk.
6. Water services tube assembly
  - A. Connect the top of the water services tube assembly to the elbow fitting located at the top of the instrument.
  - B. Connect the clear 3/8" ID tube at the top of the services tube assembly to the black hose barb located at the top of the instrument. The spiral wrap prevents the drain tube from collapsing at the bend.
  - C. Place the instrument into the water bath if not already installed.
  - D. Connect the lower SS tube of the services tube assembly to the back of the flow meter located on the top of the water control box.
  - E. Connect the drain tube at the bottom of the services tube to the tube connected to position 2 on the control box using the quick disconnect fittings provided.
  - F. Once everything is in place and correctly positioned, tighten the SS nuts with a wrench.

**Instrument Setup (Continued)**

7. Cover Disk Adjustment – This item is pre-installed and need not be adjusted.
  - A. Install a single glass condenser into the condenser holder clamp located at the top of the instrument.
  - B. Loosen the set screws in the cover disk collar so that the disk may be rotated.
  - C. Assemble one liquid / liquid Extractor set. Rotate the cover disk until the glass assembly can be placed vertically into position on the cover disk and connect to the condenser.
  - D. Push the center tube downwards against the spring at the base of the stand a distance of 6 mm (1/4") and tighten the cover disk collar set screws. When the center tube is released the cover disk should raise slightly. When fully loaded with glassware, this will reduce drag on the bath rim and allow the instrument to rotate more freely.
8. Place the hole covers onto the cover disk. They should be used whenever a glass set is not present in a position.
9. Remove all glassware from the system, if present.
10. Fill the bath with water.

### Glassware setup

**Note:** Glassware manufactured by other sources may not fit or work correctly in the ROT-X-TRACT system. Care and caution should be exercised relative to these instructions and in operation of non-Organomation Glassware in the ROT-X-TRACT system.

1. Condenser Glassware Setup Procedures – The following procedures cover setup and installation of Organomation glassware in the ROT-X-TRACT instrument.
  - A. Slide the open end of the tubes with quick disconnect fittings onto the hose barbs on the condensers (two per condenser). Secure with zip ties to prevent the tubes from popping off the condensers. When elbow QD's are present, they should face each other when installed.
  - B. Install each condenser in sequence around the water manifold. Condensers may be installed by placing the condenser in the upper most three prong clamp with the water tubes facing inwards.
  - C. Connect the water tubes on each condenser to the manifold. For optimal position, connect each fitting on the water tube to the fitting on the manifold which is three fittings to the left of the closest fitting to the condenser. Each condenser will have one water tube connected to the upper and lower manifold.
2. Assemble each extractor set as follows:
  - A. If using KD Flasks, place a 1.25" (31mm) spiral boiling chip (Organomation Boiling Grids part # GA2245) into the insulated concentrator tube. Attach the insulated concentrator tube to the bottom of the KD flask. Secure in place with the 19/22 metal clip provided.
  - B. Install the rigid Teflon Sleeve into the top of the boiling flask (KD or Round Flask).
  - C. Install the boiling flask onto the side arm of the extractor. Secure in place using the adjustable 24/40 clip.
3. Loosen the three prong clamps holding each condenser. Slide the condenser upwards until the clamp prongs are almost touching the lower condenser joint. Re-tighten the three prong clamp. Repeat for all condensers.
4. Install the extractor assembly into the unit. Clamp the extractor in place with the three prong clamp around the 45/50 joint at the top of the extractor.
5. Loosen each condenser clamp and slide the condenser downwards into each extractor.
6. Retighten the condenser clamp. Repeat for all positions.

**Instrument Controls – Water Power Control Box System**

- Power Switch -** Located on the front right panel. Turns power to the system  
Toggle Switch - On / Off operation
- Fail Light -** Located on the front right panel. Indicates water service failure.  
Red Light glows when water not flowing to condensers.
- On Light-** Located on front center panel. Indicates system power on.  
White Light glows with system powered on.
- Energy Control -** Located on front left panel. Controls bath temperature
- Power Light -** Located on front left panel. Indicates heat system activated.  
Amber Light glows when Energy Control is turned on.
- Heat Light -** Located lower left panel. Indicates power to bath .  
Amber Light glows when Energy Control sends power to the bath, will flicker on & off as power is cycled on and off.
- Reset Switch -** Located on front right panel. Bypasses low flow circuit,  
allowing water system to flow to condensers manually while depressed or until automatic system arms.  
Momentary Switch

**CONTROL BOX FRONT PANEL**

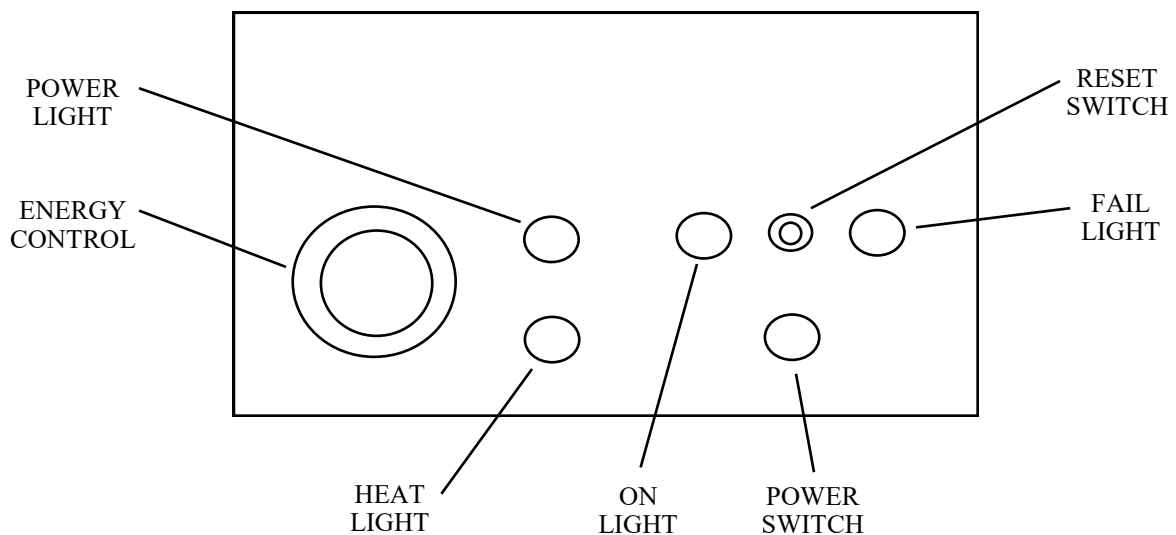

## Safety Considerations

### READ THIS SECTION BEFORE EQUIPMENT OPERATION!

This equipment is designed for use in the Analytical or Environmental Laboratory by trained laboratory personnel for evaporative applications. Use of this equipment beyond its stated intended purpose and operating parameters is not recommended and will be the sole responsibility of the user. This equipment should not be modified or altered. Organomation assumes no liability for any misuse of or modification to this product and such misuse or modification will immediately void all warranties.

This equipment should be used in accordance with the operating instructions contained in this manual. For alternative uses not covered in this manual, please contact Organomation technical department for product suitability, safety, and alternative operating instructions.

The following are general safety guidelines recommended when using this product. Please consult your laboratory safety officer for any additional safety steps which may be necessary for your specific application or material.

1. Thoroughly review your MSDS (Material Safety Data Sheets) for all chemicals to be used with this equipment.
2. Do not use this equipment with materials with auto ignition points below 150 °C.
3. Hand and eye protection are required when using this product. Additional protection may be required with respect to the materials being used. Please consult your laboratory safety officer.
4. This product should only be used in a chemical fume hood with adequate ventilation.
5. Do not move the product when hot. Scalding from bath water may result.
6. Do not open bath enclosure while energized - SHOCK HAZARD!
7. Repairs of electrical components should be conducted by a trained electrical technician. Incorrect replacement parts or assembly may damage the product and create a serious safety hazard for the user. Factory repair is strongly recommended.
8. Highly flammable materials such as Petroleum Ether should not be used with this product unless the Type-Z Purge positive pressure bath option is installed and operating.



### **Planning and Preparation**

It is important to thoroughly understand the procedures and equipment operation prior to the use of the equipment. High speed solvent extraction and evaporation requires a balance of sample volume, bath temperature, cooling water, correct setup, and adjustment. Improper use can impair performance, contaminate samples, or result in sample loss. Environmental and operating conditions are also important; examples include use of water or oil based heating media, hood airborne contaminants, glass cleaning techniques, and sample handling procedures. If you are unfamiliar with the use of the ROT-X-TRACT System or are working with a new procedure, it is recommended that a trial run be made using a sample blank to determine optimal operating conditions.

The ROT-X-TRACT System is designed to handle multiple samples simultaneously up to the capacity of the equipment (up to 8 positions).

### **CAUTION!!!**

**Samples containing ether based, fuel, munitions, or other extremely flammable or explosive materials, compounds, or residues should not be used in this equipment unless the heating unit is equipped with the TYPE -Z Purged Positive Pressure Bath Option.**

Even equipped with this option, either passive, extreme care and caution must be exercised when using these materials. The equipment must be placed in a location with adequate ventilation and safe guards, recommendations include fire suppression system, shatter proof glass, and adequate shielding for personnel. No other electronic devices should be in the same location unless they are either Z-Purge protected or are explosion proof. No flammable solvents should be stored in this location. Materials capable of forming peroxides prior to or during evaporation must be stabilized with sufficient anti-oxidant or they should not be used.

**Under no circumstances should this equipment be used with materials capable of auto ignition below 150 Degrees Centigrade including materials containing peroxides.**

**Please Contact Organomation Associates Technical Support if you have any questions concerning the use of TYPE-Z Purged equipment or questionable materials in OAI equipment.**

## Operation

1. Check bath water level, fill if necessary.
2. Turn the control box toggle switch on.
3. Adjust the energy control dial to the HI position (100% power to bath). Allow the bath to heat to the desired temperature (92 degrees Celsius recommended). The temperature control works on percentage of time the heating element is powered on. The HI position means the heaters are powered 100% of the time, while a lower setting on the dial means that the heaters are only powered some of the time, example: 50% of the time.
4. Turn on the condenser water system. Depress and hold the the reset switch. Release the reset switch. Adjust the condenser water flow to a minimum of 2500 CCM for eight positions. When operating with less than eight condensers in place and connected, the flow may be adjusted downwards. Minimum flow for one condenser installed is 1000 CCM.

Condenser water temperature should be below 10°C. When it is above this temperature, percent of solvent lost may increase. Flow may be increased to 3000 CCM if needed.

5. Assemble extractor glassware sets.
6. Load samples as follows:
  - A. Pour 300-400 ML Methylene Chloride (Dichloromethane) into the extractor body.
  - B. Carefully pour 1 Liter water sample into the extractor. Avoid getting water droplets into the extractor side return tube. Methylene Chloride will flow up the side tube and pour into the boiling flask as the water sample is added, seeking a balance point. When complete, the Methylene Chloride level in the extractor should be a minimum of 1.00" (25 mm) and there should be a minimum of 200 ML in the boiling flask. Add additional Methylene Chloride as needed. Repeat for each extractor.
7. Cover unused positions on the cover disk with the hole covers provided.
8. With the bath temperature at or above 92 Celsius and the water system running, load the extractor assemblies into the instrument.
9. Adjust the energy control as needed to maintain 92 degrees Celsius during the extraction run.

**Operation (Continued)**

10. Operate for 24 hours or as your method dictates. Acid / Base extractions may take up to 48 hours.
11. Turn off the energy control when done. Allow the system to cool for a minimum of 30 minutes before removing the extractors from the system.
12. A small amount of solvent should be used to rinse the glassware in non dryness applications.
13. Turn of the water system and power down the equipment.

**Non-dryness endpoint - Requires Evaporative Option**

Precise 1 ML endpoint operations are not possible in the ROT-X-TRACT or any other boiling solvent based system. These systems are designed as high speed multi-sample bulk evaporation systems. They provide exceptional solvent evaporation characteristics, high retention of analytes including semi-volatile materials (unlike bulk nitrogen systems which happily remove analytes, particularly semi-volatiles). Some systems offer evaporation and solvent recovery as a secondary step. Recent improvements in glassware and equipment design now allow near endpoint precision, more time for sample removal, semi-automated operation, and less sample loss. When used correctly, sample volumes can be rapidly reduced to 1.5 ML with a slow evaporation to dryness which can take nearly 5 minutes rather than 30 seconds in traditional uninsulated designs. By dropping the bath temperature 4 to 6 degrees automatically, this residency time can be increased to nearly 15 minutes. Once removed from the heat, hot solvent vapor will fall back into the concentrator, thus rinsing and cooling the glassware. Rinsing is important in recovering all materials present.

## Type Z-Purge Bath Operation - Optional

### What It Does

The Type-Z Purged system prevents ignition of flammable materials caused by contact with electrical components inside the heating unit.

### How It Works

The concept behind this purge system is to create a small positive pressure gradient inside the bath case. By carefully sealing the heating unit or control enclosure, a small flow of clean air or inert gas will create a slight positive pressure within the enclosure. It is important to note that there is constant leakage out of the enclosure. In this way the enclosure is continually purged. The pressure gradient prevents flammable vapors and occasional spills from entering the enclosure where arcing components or high surface temperature heaters might cause ignition. The use of an inert gas such as nitrogen enhances the technique by removing all oxygen from the enclosure. By purging the enclosure for 10 minutes, the gas volume within the enclosure is replaced multiple times ensuring that no flammable vapors remain which may have entered while the purge system was inactive.

### Passive

OAI currently offers one version of the Type-Z Purged system. The passive system is not tied to the electric heating system in any way. It is up to the operator to maintain the positive differential pressure within the system during operation. There is no safety interlock on failure.

### Operating Procedure

1. Turn on the gas flow to the Z-Purge System. Purge gas may be clean air or inert gas such as Nitrogen. The use of Nitrogen is recommended.
2. Adjust the gas flow until 0.5 inches water pressure is maintained on the gauge mounted on the heating unit.
3. Purge the bath for 10 minutes before engaging the electrical system.
4. After 10 minutes the gas flow may be adjusted to 0.1.
5. Turn on the electrical heating unit. The purge rate must be maintained.
6. Proceed to the next section.

### Maintenance and Cleaning

The ROT-X-TRACT evaporation system is manufactured from extremely durable materials and may last for years if operated and maintained properly. The following guidelines are recommended for use with ROT-X-TRACT systems.

Heating Media - Tap water, distilled water, de-ionized water, and bath heating oils may be used. Distilled and de-ionized water are preferred as they reduce scale and mineral buildup on bath walls.

**Do not use organic solvents as a heating medium.**

Algaecide - The use of algaecide in the bath water poses no threat to the water bath and will keep biological materials under control. Algaecide should not be acidic. Verify type of algaecide used to insure that it will not adversely affect the samples being processed.

Water Changes - The bath water should be changed once per week (recommended), but not less than once per month.

Cleaning - The stainless steel components may be cleaned with an abrasive or scouring pad followed by rinsing with clean water.

Acidic Environment - When in contact with or exposed to acidic materials, vapors, or samples. The instrument should be cleaned immediately after use and neutralized with a suitable mild base solution of sodium bicarbonate or similar material followed by a clean water rinse. Prolonged contact with acidic materials may damage the instrument unless precautions are taken.

Immersion - The bath case is water resistant, not water tight. Under no circumstances should the bath be immersed in any liquid or placed in a location where this may occur.

<b>SYMPTOMS</b>	<b>CAUSES</b>	<b>SOLUTIONS</b>
<b>No Power to bath.</b>	Electrical outlet not energized. Bath power cord not plugged in. Internal electrical fault.	Energize electrical outlet. Plug in bath power cord. Contact factory for instructions.
<b>Bath does not heat.</b> (heat light is on)	Bad wire connection. Defective high temperature protection switch. Defective thermostat control	Bath will require service, contact factory for instructions.
<b>No temperature control.</b> (temperature continues to rise)	Defective thermostat control	Replace thermostat, contact factory for instructions.
<b>Bath will not heat above 65 - 75 C.</b>	Open faced bath, no cover disk. One of two heaters defective. Defective high temp. switch Defective temperature control.	Purchase anti-evaporation floats. Replace heater, switch, or thermostat, contact factory for instructions.
<b>Water inside bath.</b>	Water floods in hood. Leaky thermocouple fitting. Bath surface spill. Pinhole in bath pan.	Consult factory. Disassemble bath, dry all contents thoroughly. Return for service highly recommended.
<b>Rust in bath or equipment.</b>	Use of acidic materials in or near equipment.	Clean carefully with steel wool. Remove source of acidic presence.
<b>Phthalate Contamination</b>	Human error	Exercise better handling procedures, avoid latex gloves, hand cream, rubber tubing.
<b>Inconsistent evaporation rates.</b>	Variable bath temperatures.	Check operating conditions.
<b>Biological growths in bath</b>	Algae, molds, etc. in bath water	Use algaecide, change bath water once per week.

## Service and Returns

In the event a product purchased from Organomation needs service or must be returned please follow the outlined procedures below.

### 1) **Contact Organomation Technical Support Department**

Before returning any product to Organomation Associates for any reason, please contact the Technical Support Department, toll free at 888-838-7300 or email [sales@organomation.com](mailto:sales@organomation.com) Support is available Monday through Friday from 8:30 AM to 4:30 PM EST. Support is available free of charge to customers of Organomation in good standing for all products manufactured by Organomation.

### 2) **Pack the product for return shipment**

The product should be packaged in its original shipping carton if available. If other packaging is required, use a suitable shipping container which will allow a minimum of two (2) inches clearance between the product and the side walls of the shipping carton. Peanuts, semi rigid foam, cardboard, and other items may be used inside for packaging. Care should be taken when packaging heavy items. Some packaging, such as peanuts, will allow the item to shift in transit and may result in damage.

### 3) **Insurance**

Most common carriers offer insurance. UPS and Federal Express automatically insure your product up to \$100.00 without charge. It is highly recommended that you insure your product. **Organomation is not liable for any return shipping damages.**

### 4) **Documentation**

When returning items to Organomation, a Return Authorization Form must be included with the following information: Contact persons name and phone number, return address, and statement of the problem.

### 5) **How will your return be handled?**

Organomation will evaluate the returned item for damage. If the return is a repair, the product will be examined for problems and a repair estimate will be made. The contact person will be contacted, at which time a Purchase Order will be requested. After the PO is issued, the product will be repaired and return shipped. Most repairs are done within a 24 hour period. Return for credit items will be evaluated and your account credited after the item is received. The contact person will be notified immediately in the event shipping damage has occurred.

**Shipping - Claims for damage and shortage**

Organomation makes a sincere effort to ensure your purchase is properly packed and all items listed on the packing slip are in fact enclosed with the shipment. In the event that your purchase is damaged or if any items are missing, please follow the procedures below.

- 1) All packaging materials must be retained until the issue is resolved.
- 2) Thoroughly search all packing materials for the missing items. Review your packing list for back ordered items and the manual for a list of items affiliated with your purchase.
- 3) Contact Organomation immediately at 888-838-7300 or email sales@organomation.com
- 4) If a damaged item needs to be replaced, Organomation will send this item under warranty at no charge. The damaged item must be returned to Organomation. Please follow the instructions listed in the Service and Returns section. **Important - items not returned or which are damaged or destroyed in transit are the responsibility of the customer and will be billable.**
- 5) No claims for shipping damage or shortage will be accepted after 15 days of receipt of the items by the purchaser.

All items should be returned to:

**Organomation  
266 River Road West  
Berlin, MA 01503**



**Specifications**

- Electrical Requirements:** 120 or 240 VAC single phase, non switchable, 50 - 60 Hz.  
3 wire grounded outlet required.  
Model 13308 8 Position Bath 1400 W\*  
\* 240V units divide wattage by 2.
- Electrical Compliances:** EC compliance EN55014.
- Water Services Required:** Regular tap, distilled, or de-ionized water required.  
Bath water level maintenance device.  
50 - 65 deg F cooling water 1 - 2.5 LPM
- Gas Services Required:  
(Z-Purge only)** Nitrogen, clean air, or other inert gas,  
5 - 30 Psig, adjustable.  
Quiet air compressor available.
- Sample Sizes Accepted:** 1 Liter L / L Extractor
- Sample Types Utilized:** Water / Methylene Chloride (Dichloromethane)
- Safety Provisions** 3 wire grounded power cord.  
High Temperature Protection Switch  
Stainless Steel construction.  
Optional Type-Z positive pressure bath purge.

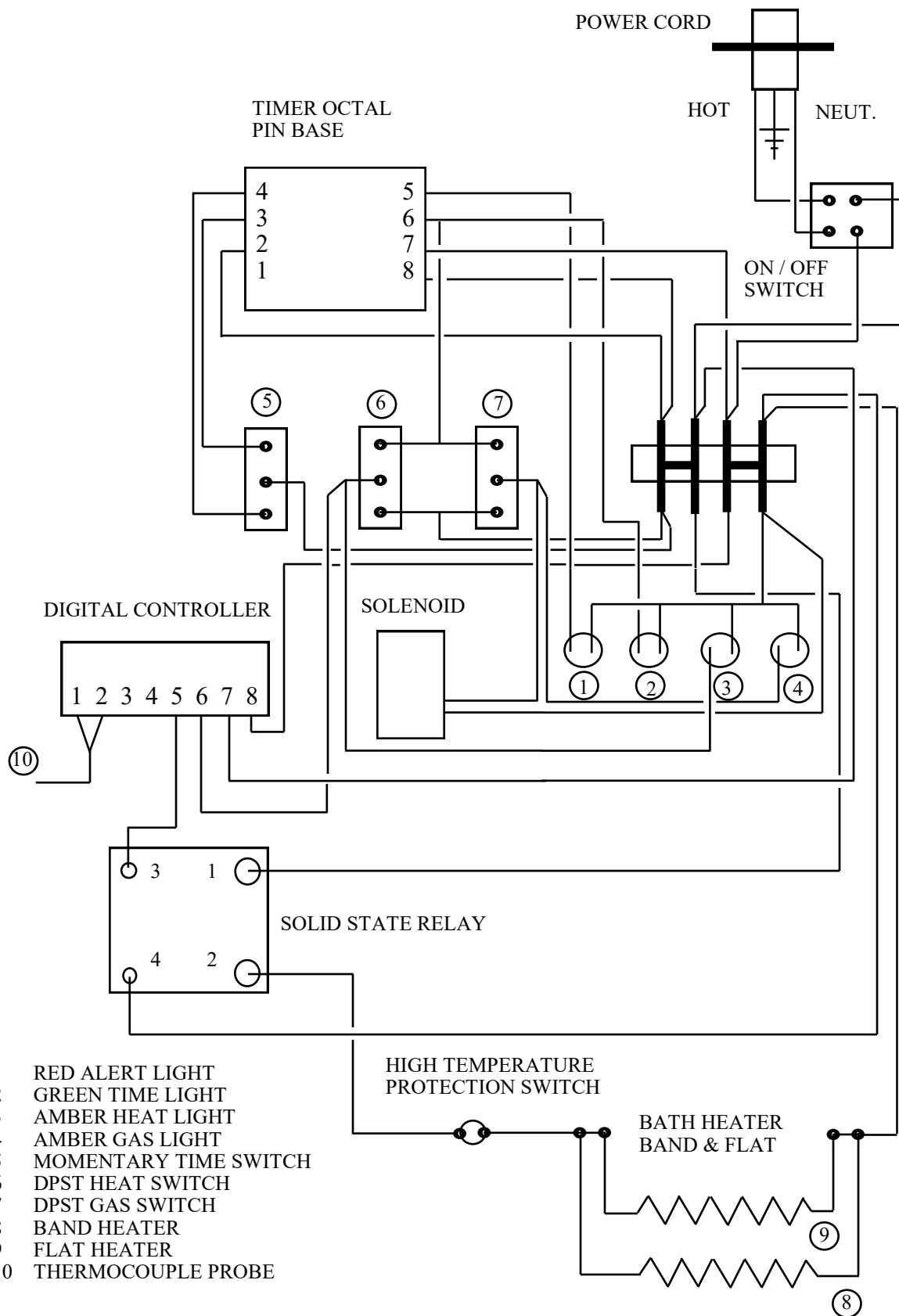

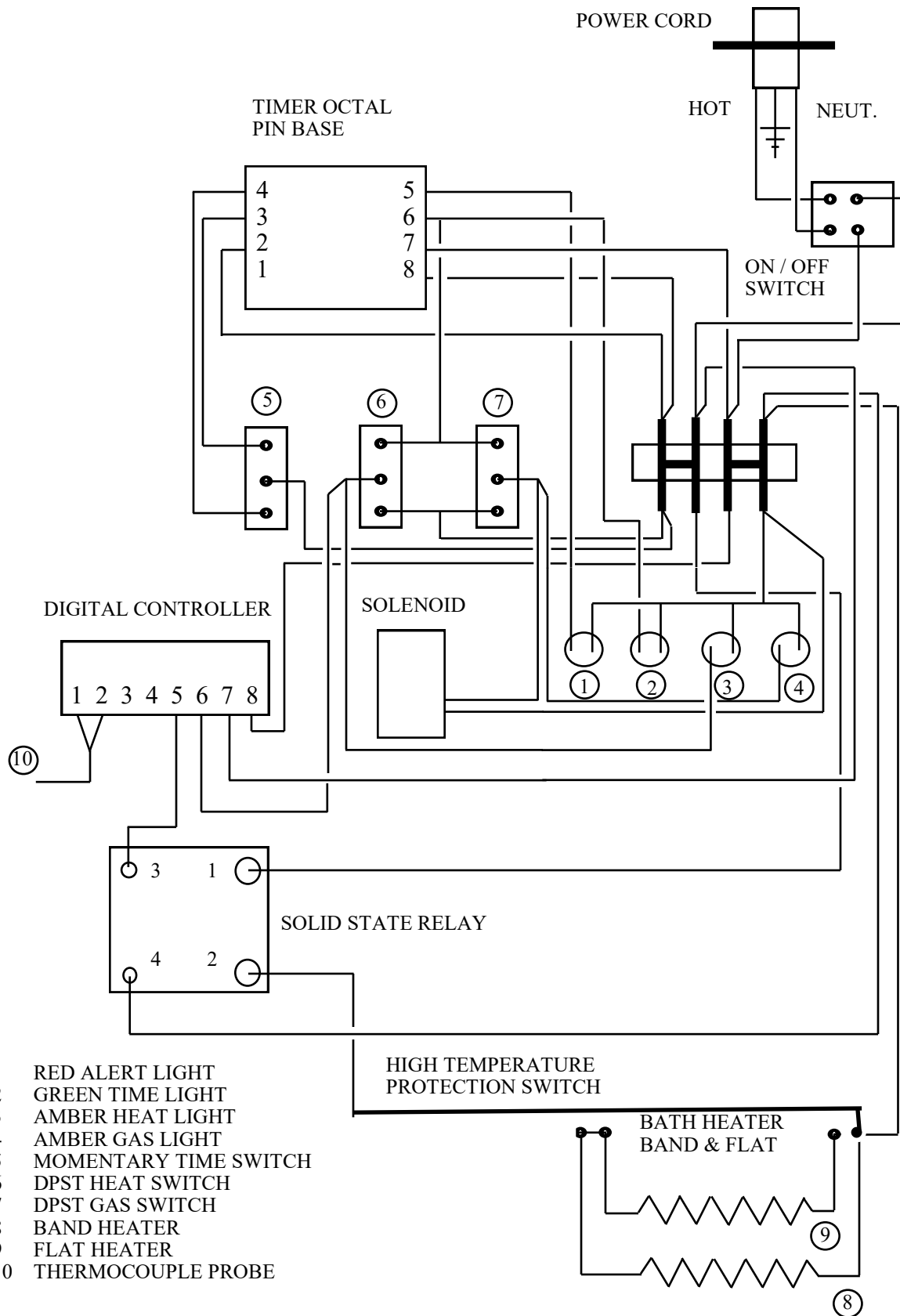

## CE Declaration of Conformity Revised June 1, 2015

We, Organomation Associates Inc a corporation registered in Massachusetts, United States of America, declare under sole responsibility that the following equipment to which this declaration relates, meets the principal protection requirements and is in conformity with relevant sections of the applicable CE standards and other normative documents. If changes are made to the products covered by this declaration then the declaration is no longer valid.

Equipment type: Laboratory sample preparation instruments.  
Bench top size, multiple sample position.  
Analytical evaporators and extractors.

Model(s): N-EVAP Nitrogen evaporator models:  
11106, 11155, 11250, 11634, 11645  
MULTIVAP Nitrogen evaporator models:  
11364, 11300, 11809, 11830, 11848, 11880  
11801, 11803, 11815, 11824  
S-EVAP solvent evaporator models:  
12060, 12080, 12008  
12027, 12037, 12010, 12018, 12048  
  
Rot-X-Tract-S solid-liquid extractor models:  
13070, 13090, 13008  
Rot-X-Tract-L liquid-liquid extractor models:  
13318, 13308

All of the above wired for 110 and 220 volts (-2 option code).  
All of the above with dry bath and aluminum beads (-DA option code).  
All of the above with acid resistant coatings (-RT option code).  
All of the above with positive pressure, purged bath case (-Z option code).

EC Directives and Amendments: 89/336/EEC - Electromagnetic Compatibility Directive (EMC).

Harmonized Standards and IEC publications used: EN61326, EN61010-1

Authorized signature



Title

President

Date

June 1, 2015